



## *K Line*

**EN**

### *K121*

**Universal isolated transmitter  
with 2 wire - loop powered**

## *Installation Manual*

### **Contents:**

- General specifications
- Technical features
- Diagram: Load resistance vs minimum functioning voltage.
- Installation / Connections rules
- Electrical connections
- Table: Input range and accuracy of measure
- Factory settings and advanced settings.

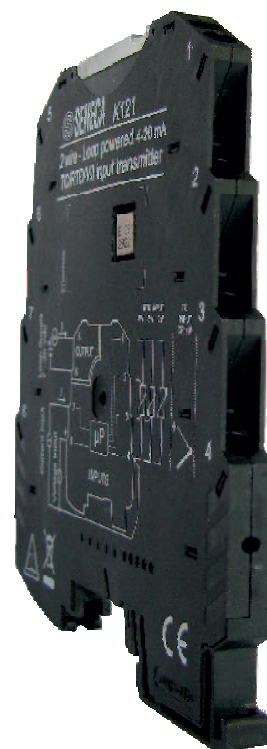

### **SENECA s.r.l.**

Via Austria, 26 - 35127 - PADOVA - ITALY

Tel. +39.049.8705355 - 8705359 - Fax +39.049.8706287

For manuals and configuration software, see [www.seneca.it](http://www.seneca.it)

This document is property of SENECA srl. Duplication and reproduction are forbidden, if not authorized. Contents of the present documentation refers to products and technologies described in it. All technical data contained in the document may be modified without prior notice Content of this documentation is subject to periodical revision.

## GENERAL SPECIFICATIONS

- Conversion and transmission of the input read into a normalized signal current in the output for the loop 4 ..20 mA that is connected with 2 wire connection.
- Thermocouple input J, K, R, S, T, B, E, N ( EN 60584 ).
- RTD input (PT100 - 500 - 1000, Ni100) with 2, 3 o 4 wire connections.
- Voltage input  $\pm 30$  V.
- Voltage input  $\pm 150$  mV
- Current input  $\pm 24$  mA.
- Potentiometer input with resistance between 500  $\Omega$  and 10 K $\Omega$ .
- Resistance input up to 1760  $\Omega$ .
- Reduced response time (Voltage and Current input): 140 ms
- Reduced response time (Other inputs): < 620 ms
- High precision.
- 16-bit measurement conversion.
- 1500 Vac output isolation.
- Compact size 93 x 102,5 x 6,2 mm.

## TECHNICAL FEATURES

### Output / Power supply

|                              |                                                                                                |
|------------------------------|------------------------------------------------------------------------------------------------|
| Power supply                 | 7 ..30 V <sub>DC</sub>                                                                         |
| Power consumption            | < 660 mW                                                                                       |
| Current output               | 4 ..20 mA                                                                                      |
| Load resistance              | 1 k $\Omega$ @ 28 Vdc, 21 mA (see the diagram Load resistance vs minimum functioning voltage). |
| Resolution                   | 2 $\mu$ A (> 13 bit)                                                                           |
| Temperature Coefficient      | < 100 ppm, typical 30 ppm                                                                      |
| Output in case of over-range | + 2,5% of end scale, - 2,5% of start scale                                                     |
| Output in case of fault      | + 5% of end scale, - 5% of start scale                                                         |
| Current output protection    | ~ 30 mA                                                                                        |

### Potentiometer input

|                        |                                    |
|------------------------|------------------------------------|
| Value of potentiometer | From 500 $\Omega$ to 10 k $\Omega$ |
| Input impedance        | 10 M $\Omega$                      |

### Thermocouple input

|                            |                                           |
|----------------------------|-------------------------------------------|
| Input impedance            | 10 M $\Omega$                             |
| Cold junction compensation | -40 ..65 $\pm$ 1,5 $^{\circ}$ C; Settable |
| Sensor fault detection     | Yes; Settable                             |

### RTD input / Resistance

|                                     |                       |
|-------------------------------------|-----------------------|
| Excitation current                  | 375 $\mu$ A           |
| Maximum cable resistance            | 25 $\Omega$           |
| Influence cable resistance <i>e</i> | 0,003 $\Omega/\Omega$ |

## Voltage (mV) input

|                 |               |
|-----------------|---------------|
| Input impedance | 10 M $\Omega$ |
| Input range     | -150 ..150 mV |

## Voltage (V) input

|                 |                |
|-----------------|----------------|
| Input impedance | 200 k $\Omega$ |
| Input range     | -30 ..30 Vdc   |

## Current input

|                 |             |
|-----------------|-------------|
| Input impedance | 40 $\Omega$ |
| Input range     | -24 ..24 mA |

## Environmental condition

|                       |                                |
|-----------------------|--------------------------------|
| Operating temperature | -20 ..+65°C                    |
| Humidity              | 30 ..90% a 40°C non condensing |
| Storage temperature   | -20 ..+85°C                    |
| degree protection     | IP20                           |

## Connections

|             |                    |
|-------------|--------------------|
| Connections | 8 Spring terminals |
|-------------|--------------------|

## Dimensions / Box

|            |                                  |
|------------|----------------------------------|
| Dimensions | L: 93 mm; H: 102,5 mm; W: 6,2 mm |
| Box        | PBT, Black                       |

## Isolation 1500 V

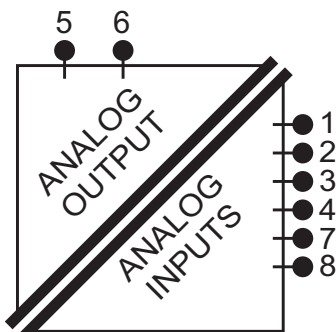

## Standards

The module is conforming to the following regulations:



**EN61000-6-4/2002** (Electromagnetic emission, industrial environment).

**EN61000-6-2/2006** (Electromagnetic immunity, industrial environment).

**EN61010-1/2001** (safety).

### SUPPLEMENTARY NOTE FOR USE:

Use in environment with 2 or less pollution degree.

# DIAGRAM: LOAD RESISTANCE VS MINIMUM FUNCTIONING VOLTAGE

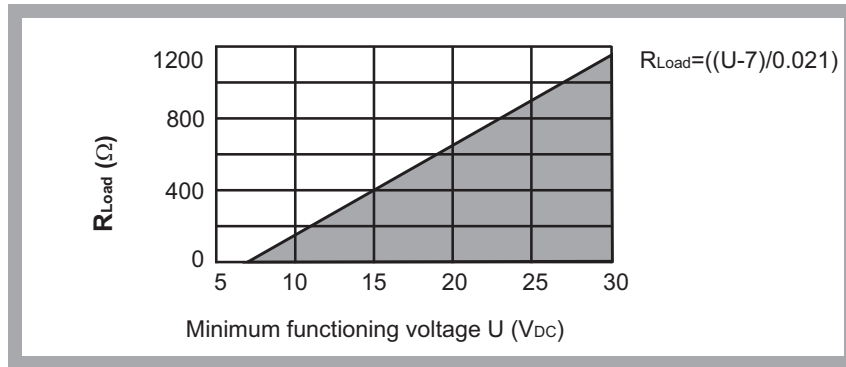

Fig. 1

## INSTALLATION / CONNECTIONS RULES

### Installation on DIN46277 rail

The module is designed to be installed, in vertical position, on DIN 46277 rail. For the best module performance and duration, avoid to place cables raceways and other objects that could obstruct the ventilation.

Never install the modules near heat sources. The module installation is advised in the bottom of the control panel.

#### Inserting the module in the rail

#### Removing the module from the rail

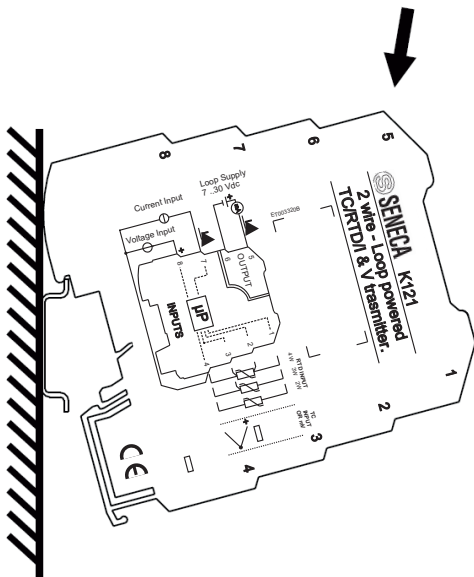

Fig.2a

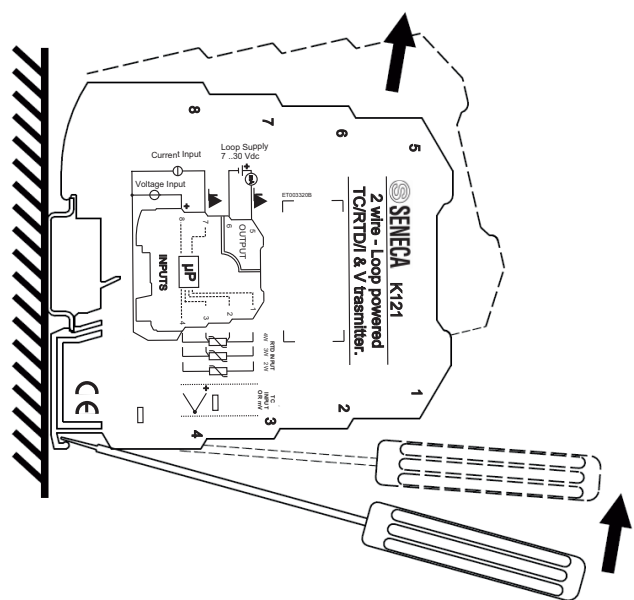

Fig. 2b

1) Attach the module in the upper part of the rail (as shown in the picture 2a).

2) Press the module downwards.

1) Apply leverage using a screwdriver ( as shown in the picture 2b)

2) Rotate the module upwards.

## Connections with spring terminals

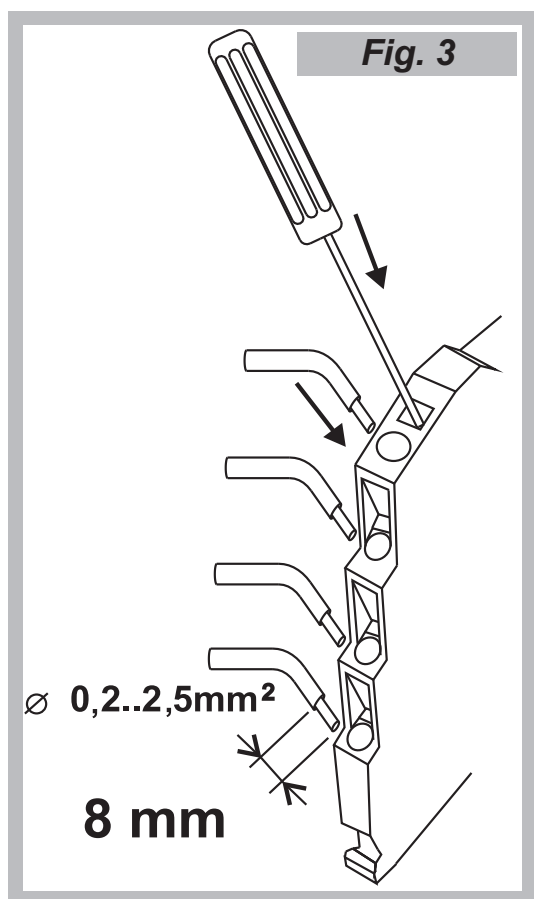

The module has been designed for spring-type terminal electrical connections:  
Proceed as follows to make the connections:

- 1) Strip the cables by 0.8 mm.
- 2) Insert a screwdriver in the square hole and press it until the cable lock spring opens..
- 3) Insert the cable in the round hole.
- 4) Remove the screwdriver and make sure that the cable is tightly fastened in the terminal.

## ELECTRICAL CONNECTIONS

### Input

#### **Description**

The signal input may come from thermocouple J, K, R, S, T, B, E, N (EN 60584) sensors or RTD (thermoreistance) like Pt100, Ni100, Pt500, Pt1000 and Ni100. K121 besides can read voltages in V and mV, current in mA, and resistances.

For the maximum performance it's recommended to use a shielded cable.

See Fig. 4 below for input connections.

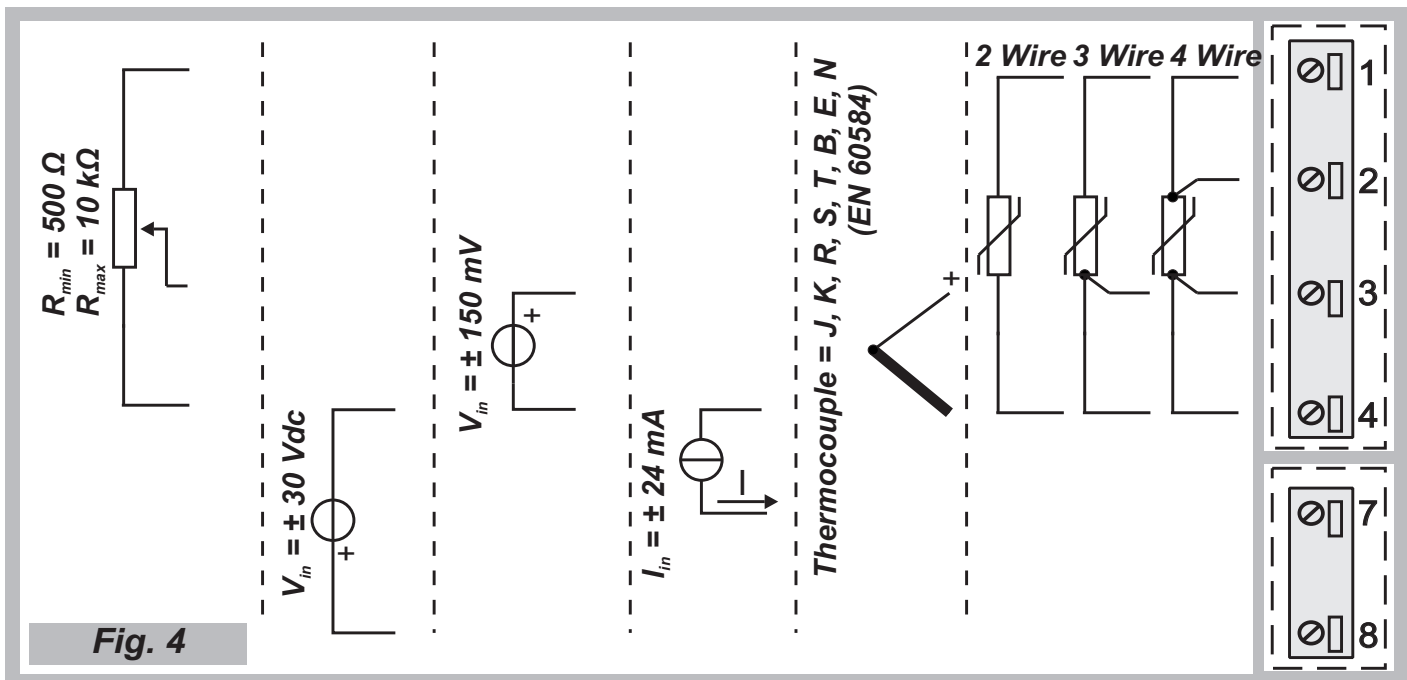

Fig. 4

### RTD 2 wire connection

This connection can be used for short distances ( $< 10$  m) between module and probe, you should note that it adds an error (which may be removed by software programming) equivalent to the resistance contributed by the connection cables to the measurement.

The module must be programmed by PC for 2 wire connection

### RTD 3 wire connection

This connection can be used for medium-long distances ( $> 10$  m) between module and probe. The instrument performs a compensation for the resistance of the connection cables. For a correct compensation the resistance value of each conductor must be the same.

The module must be programmed by PC for 3 wire connection.

### RTD 4 wire connection

This connection can be used for medium-long distances ( $> 10$  m) between module and probe. Provides the maximum precision because the instrument measures the resistance of the sensor independently of the resistance of the connection cables.

The module must be programmed by PC for 4 wire connection.

## Output and power supply from loop 4 ..20 mA

Current Loop connection (regulated current).

The use of shielded cables is recommended for the electric connections.

Note: in order to reduce the instrument's dissipation, we recommend guaranteeing a load of  $> 250 \Omega$  to the current output.

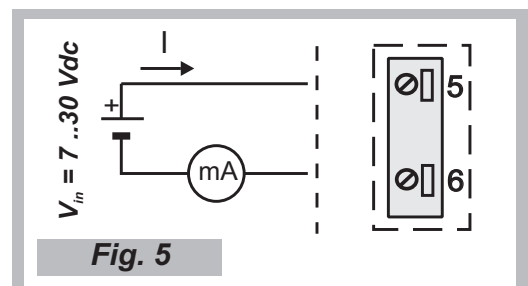

Fig. 5

## Table: Output signal limit / fault or over-range

| Output signal limit | Over-range / $\pm 2,5 \%$ | Fault $\pm 5 \%$ |
|---------------------|---------------------------|------------------|
| 20 mA               | 20,4 mA                   | 21 mA            |
| 4 mA                | 3,6 mA                    | $< 3,4$ mA       |

**TABLE: INPUT RANGE AND ACCURACY OF MEASURE**

|              | Input  | Range         | Calibration error | EMI     | Minimum Span | Resolution | Standard  |
|--------------|--------|---------------|-------------------|---------|--------------|------------|-----------|
| Thermocouple | J      | -210..1200 °C | 0,1 %             | < 0,5 % | 50 °C        | 5 µV       | EN 60584  |
|              | K      | -200..1372 °C | 0,1 %             | < 0,5 % | 50 °C        | 5 µV       | EN 60584  |
|              | R      | -50..1768 °C  | 0,1 %             | < 0,5 % | 100 °C       | 5 µV       | EN 60584  |
|              | S      | -50..1768 °C  | 0,1 %             | < 0,5 % | 100 °C       | 5 µV       | EN 60584  |
|              | T      | -200..400 °C  | 0,1 %             | < 0,5 % | 50 °C        | 5 µV       | EN 60584  |
|              | B (*)  | 0..1820 °C    | 0,1 %             | < 0,5 % | 100 °C       | 5 µV       | EN 60584  |
|              | E      | -200..1000 °C | 0,1 %             | < 0,5 % | 50 °C        | 5 µV       | EN 60584  |
|              | N      | -200..1300 °C | 0,1 %             | < 0,5 % | 50 °C        | 5 µV       | EN 60584  |
| RTD          | Ni100  | -60..250 °C   | 0,1 %             | < 0,5 % | 20 °C        | 6 mΩ       | DIN 43760 |
|              | Pt100  | -200..650 °C  | 0,1 %             | < 0,5 % | 20 °C        | 6 mΩ       | EN 60751  |
|              | Pt500  | -200..650 °C  | 0,1 %             | < 0,5 % | 20 °C        | 28 mΩ      |           |
|              | Pt1000 | -200..200 °C  | 0,1 %             | < 0,5 % | 20 °C        | 28 mΩ      |           |
| Voltage      | mV     | -150..150 mV  | 0,1 %             | < 0,5 % | 2,5 mV       | 5 µV       |           |
| Potent.      | Ω      | 500.. 10000Ω  | 0,1 %             | < 0,5 % | 10 %         | 0.0015 %   |           |
| Resist.      | Ω      | 0..400 Ω      | 0,1 %             | < 0,5 % | 10 Ω         | 6 mΩ       |           |
| Resist.      | Ω      | 0..1760 Ω     | 0,1 %             | < 0,5 % | 10 %         | 28 mΩ      |           |
| Voltage      | V      | -30 ..30 Vdc  | 0,1 %             | < 0,5 % | 0,5 V        | ~ 1 mV     |           |
| Current      | mA     | -24 ..24 mA   | 0,1 %             | < 0,5 % | 0,5 mA       | ~ 1 µA     |           |

(\*) Termocouple type B: From 0 °C to 250 °C the measurement is zero.

### Table of accuracy measure: The greater of the sum of (A+B) and C

| Input type               | A : % of measure | B : % of span | C : Minimum |
|--------------------------|------------------|---------------|-------------|
| Thermocouple J,K,T,N,E   | 0.05 %           | 0.05 %        | 0.5 °C      |
| Thermocouple B, R, S     | 0.05 %           | 0.05 %        | 1 °C        |
| RTD                      | 0.05 %           | 0.05 %        | 0.1 °C      |
| Resistance F.S. = 400 Ω  | 0.05 %           | 0.05 %        | 40 mΩ       |
| Resistance F.S. = 1760 Ω | 0.05 %           | 0.05 %        | 200 mΩ      |
| Voltage mV               | 0.05 %           | 0.05 %        | 15 µV       |
| Potentiometer            | 0.05 %           | 0.05 %        | 3 mV        |
| Voltage V                | 0.05 %           | 0.05 %        | 3 mV        |
| Current                  | 0.05 %           | 0.05 %        | 2 µA        |

# FACTORY SETTINGS AND ADVANCED SETTINGS

## Factory settings

- Cold junction compensation: YES.
- Input filter: DISABLE.
- Reversed output: NO.
- TC Type: K.
- Measurement range start: 0°C.
- Measurement full-scale: 1000 °C.
- Output signal in case of fault: Towards the top of the output range.
- Over-range: YES, at 2,5% over-range values is accepted, at 5% over-range value is considered a fault.

## Advanced setting

- Setting of the start scale and full scale value.
- RTD: 2 wire, 3 wire, 4 wire connections.
- Measure filter: Enable / Disable
- Output: Normal (4 ..20 mA) or reversed (20 ..4 mA).
- Selection of input type.
- Cable resistance compensation for 2 wires measurement.
- Output signal in case of fault: towards the bottom or towards the top of the output range
- Over-range: NO (the fault alone causes at 2,5% over range value) or YES (at 2,5 over-range value is accepted, at 5 % over range value is considered a fault).
- Cold junction compensation: YES / NO.

## Software configuration

The configuration by PC use (see the drawing below) is possible with the following accessories

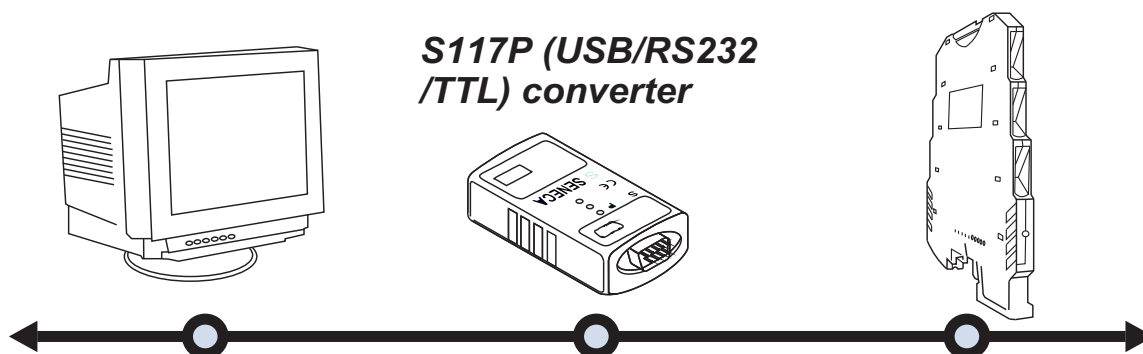

Variations of standard parameters are possible by using configuration softwares. See [www.seneca.it](http://www.seneca.it) to consult the download section.



Disposal of Electrical & Electronic Equipment (Applicable throughout the European Union and other European countries with separate collections programs). This symbol, found on your product or on its packaging, indicates that this product should not be treated as household waste when you wish to dispose of it. Instead, it should be handed over to an applicable collection point for the recycling of electrical & electronic equipment. By ensuring this product is disposed of correctly, you will help prevent potential negative consequences to the environment and human health, which could otherwise be caused by inappropriate disposal of this product. The recycling of materials will help to conserve natural resources. For more detailed information about the recycling of the product, please contact your local city office, waste disposal service of the retail store where you purchased this product.