

E TEST-4 VOLTAGE/CURRENT MEASUREMENT DEVICE - GENERATOR WITH OLED DISPLAY.

General Description

The Test-4 instrument is a process calibrator that generates (even in the ramp mode) or measures the canonical variables of an industrial process, voltage between 0 and 11 V and current between 0 and 21 mA. The instrument also enables displaying the values measured or generated via MODBUS-RTU protocol.

The Test-4 can be powered by two rechargeable NiMH batteries that ensure a minimum 8 hours range at full charge or by the mains at 220 V through the special power supply unit/battery charger.

The menu allows the user to set the operating mode (Generation or Measurement) and the type of signal (Voltage or Current). The user can also choose the language (Italian, English, French, German and Spanish) and other parameters such as contrast and sensitivity of the dial.

Test-4 is equipped with two keys to **Confirm** or **Exit** an operating mode, and a dial for setting the value of electrical variables generated or to browse the menu options.

The only two bushes on the top are used both for generation and measurement. Instead, the micro AB USB connector enables communication or acquisition of data through ModbusADD#1, 9600,8,N,1*, by default.

Technical Specifications

Power supply:	-2 NiMH type AA batteries 2650mAh, Minimum lifetime: 8 hours at maximum load (*). -From 220 Vac mains through a power feeder/battery charger.
Consumption:	Max 300 mA
Battery Charger:	6 V, 300 mA stabilised (central positive)
Input/Output:	Voltage: 0..11 V, Current: 0.021 mA Protection: $\pm 30V$
Serial communication ports:	USB, 9600 Baud, Address: 1, Parity: NO, Data: 8 bit, Stop bit: 1, MODBUS-RTU
Protocol:	0.1 % for all IN/OUT signals
Precision:	At both 50 Hz and 60 Hz
Rejection:	10 Hz
Sampling Frequency:	IP20
Protection rating:	Temperature 0..50 °C Humidity 30..90 % non condensing Altitude: up to 2000 m a.s.l.
Environmental conditions:	-In/Out: Bushes, Power supply: Battery compartment at rear (under the cover in protective rubber). -microAB communication USB.
Connections:	

(*): For the first time, the batteries must be charged for at least 12 hours

Dimensions, Weight:	140 x 75 x 33 mm, 250 g.
Standards:	EN61000-6-4 (electromagnetic emission, industrial surroundings) EN61000-6-2 (electromagnetic immunity, industrial surroundings) EN61010-1 (safety)

Operating Logic
Test 4 is an instrument able to:
-Measure voltage/current/active current.
-Generate voltage/current/passive current, even in "ramp" mode.

Instrument Control
Test-4 is equipped with two buttons and a dial. Below is shown the layout of the instrument:

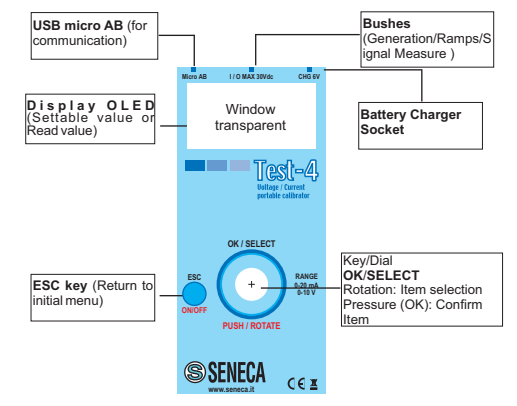

Measure / Generation of voltage or active/passive current

Test-4 is an instrument able to:
• Measure voltage in the range 0..11 V.
• Measure current in the range 0..21 mA.
• Generate current within the range 0..21 mA, powered by the loop.
• Generate voltage within the range 0..11 V, even in "ramp" mode.
• Generate current within the range 0..21 mA, even in "ramp" mode.
• Generate current within the range 0.21 mA, powered by the loop, even in "ramp" mode.
• Reading of voltage is restricted to -0.2 V to +11 V, whereas for current, the ranges are from 0.1 mA to +21 mA. Linearity is not ensured outside the nominal ranges of 0..20 mA and 0..10 V. The operation of the instrument is set by user's selections in the menu. If a voltage or current value is being read, the value respectively in mA or Volts is shown directly on the display.

Example: Setting value during generation
If generating current or voltage, turn push-button **OK/SELECT** clockwise to increase the set value, or anti-clockwise to reduce it conversely, by pressing the same push-button, you can vary the position of the figure being modified (value*1, value*10, value*100, value*1000).
The modification of the position is indicated by an arrow under the relative figure.
Rotation of the dial enables the user to display the selected value. For example, we have:

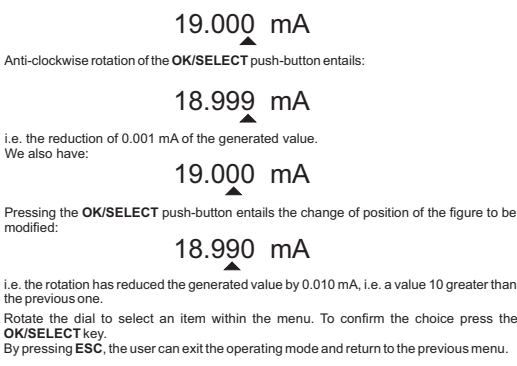

FAST NAVIGATION DIAL CONTROLS

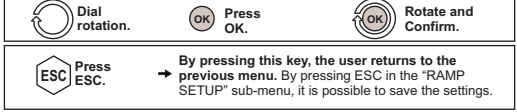

SCHEMES FOR SETTING THE TEST-4 DURING GENERATION

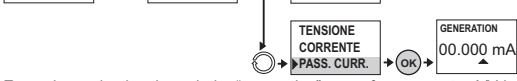
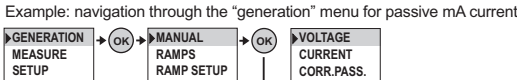
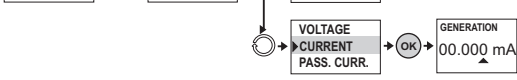
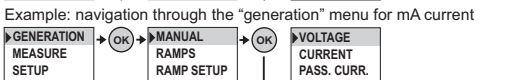

Example: navigation through the "generation" Ramp setup mA/Vdc

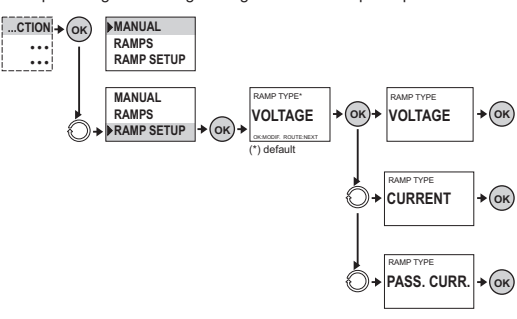

Example: navigation through the "generation" menu Parameter ramp setup

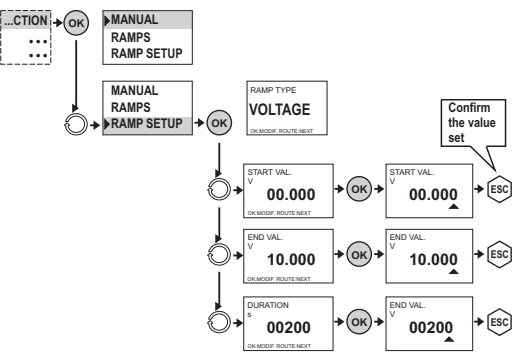

SCHEMES FOR SETTING THE TEST-4 DURING MEASUREMENT

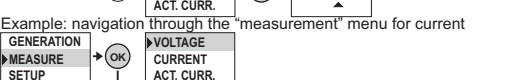
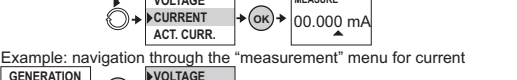
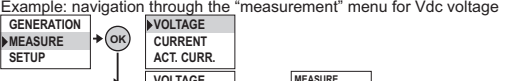
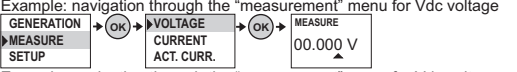

SCHEMES FOR SETTING THE TEST-4 DURING SETUP

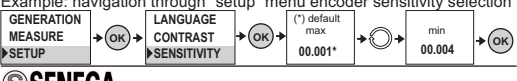

ELECTRICAL CONNECTIONS

Wiring diagrams: GENERATION
The following are the wiring diagrams with the instrument set as generator:

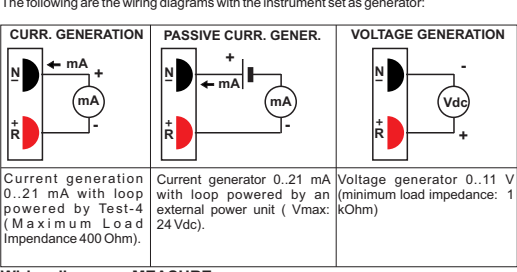

Wiring diagrams: MEASURE
The following are the wiring diagrams with the instrument set for measuring current or voltage signals:

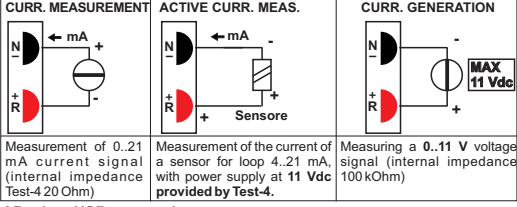

AB micro USB connection

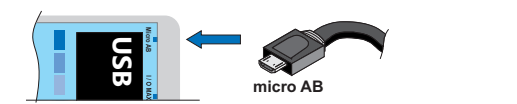

Power supplied by the power unit supplied 6Vdc, 500 mA

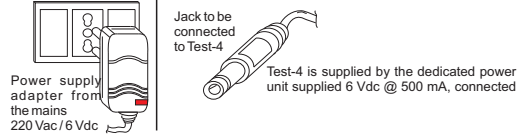

ADVANCED SETTINGS AND SIGNALS

Screen saver
• Set Screensaver: after one of the keys has not been used for 6-7 minutes, the video content is scrolled vertically until one of the buttons is pressed. During generation or measurement the values are written again with minimum contrast. During generation, the user can exit the Screensaver mode without modifying the value generated, by pressing the dial button. During measurement, the user can exit the Screensaver by turning the dial or by pressing any button.
• Set Auto Off: If you hold down the dial button in the start menu for more than 4 seconds, the instrument will switch from Auto Off On mode to Auto Off Off mode or vice versa. This configuration will remain saved in the memory as well. In Auto Off ON mode, after 6-7 minutes of inactivity, the screensaver will not be set but the instrument will turn off automatically. Default Auto off OFF.

Error signalling

Any errors will be shown directly on display. Below are given the possible signals and their meaning:
Messages during measurement or generation:
• **OVER VOLTAGE:** voltage read exceeds 11 V.
• **UNDER VOLTAGE:** voltage read below -0.2 V.
• **OVER CURRENT:** current read exceeds 21 mA.
• **UNDER CURRENT:** current read below -0.1 mA.
• If, for example, you wish to generate a voltage and, for some reason (e.g. the prods are short circuited with each other), the instrument cannot impose it, the indicator of the type of generation will start to flash, indicating an unreliable generation value.

Disposal of electrical and electronic equipment (applicable throughout the European Union and other European countries with separate collection programs). This symbol, found on your product or on its packaging, indicates that this product should not be disposed of as household waste. Instead, it should be handed over to an applicable collection point for the recycling of electrical and electronic equipment. By ensuring this product is disposed of correctly, you will help prevent potential negative consequences to the environment and human health, which could otherwise be caused by inappropriate disposal of this product. The recycling of materials will help to preserve natural resources. For further information on how to recycle this product, please contact your local city office, waste disposal service or the retail store where you purchased this product.